



ISO 9001:2008  
Zert.-Nr. 01 100 89747



Metall- und Plastikverarbeitungs- GmbH & Co. KG Kierspe

Internet: [www.mpk-kierspe.de](http://www.mpk-kierspe.de)



ISO 14001:2004  
Zert.-Nr. 01 104 069609

# Fitting and Operating Instructions



Rooflight Model 42, 46/ 4600, 44/ 4400

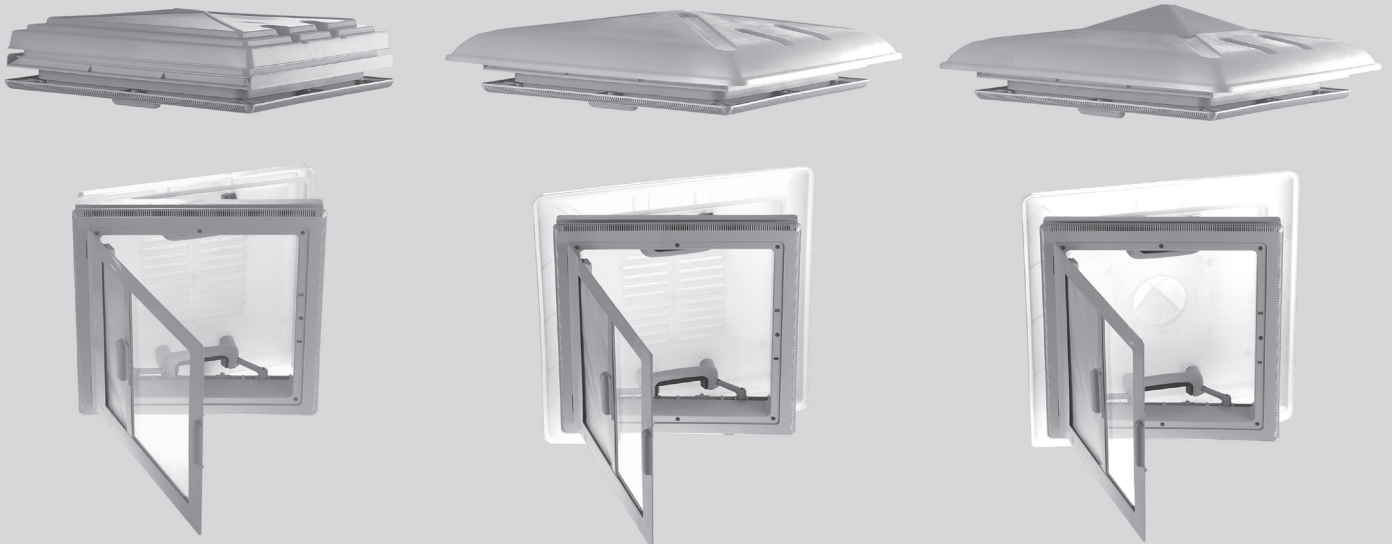

## Illustration

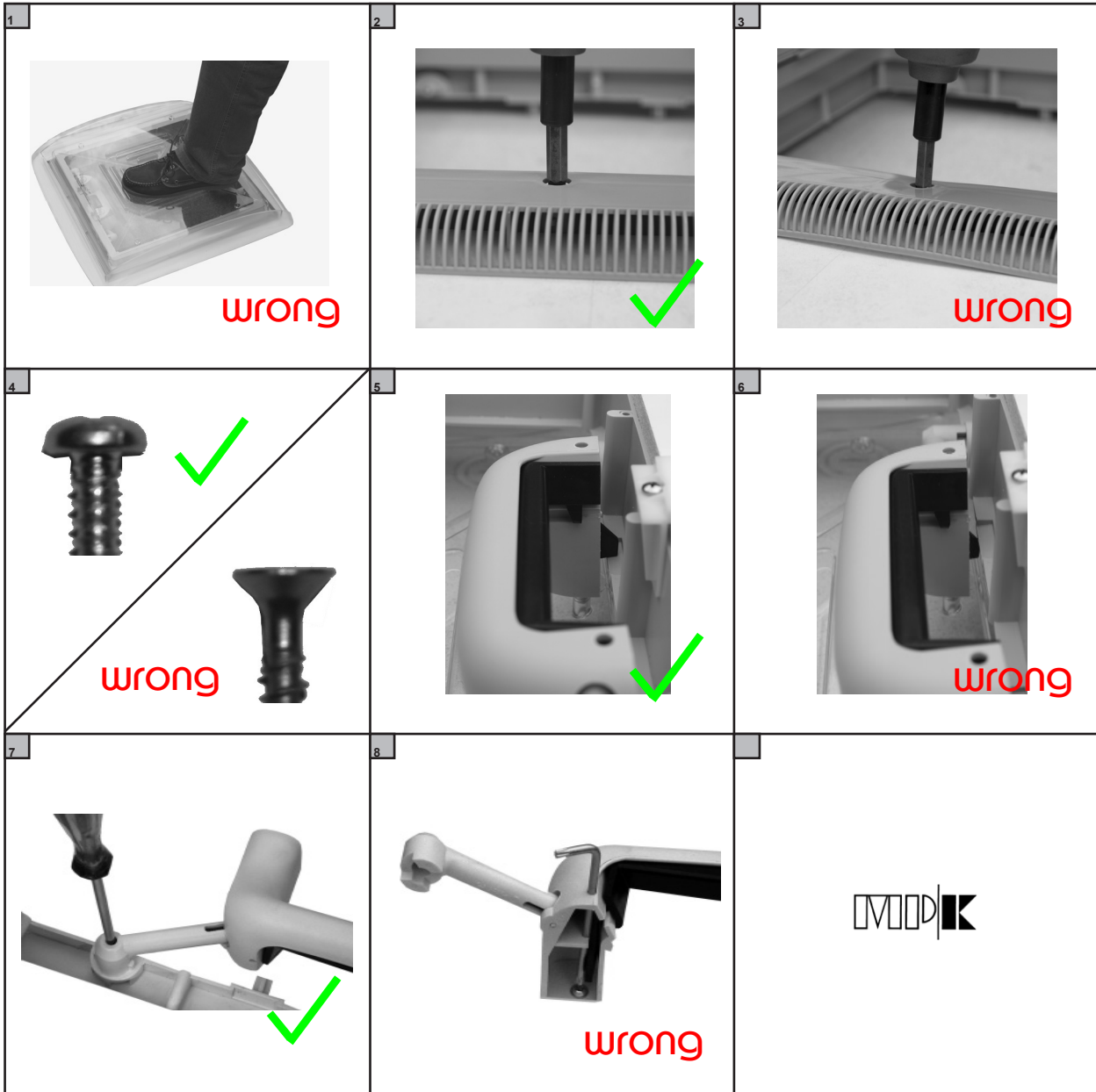

**We only recommend installation by authorised dealers.**

**Please read these instructions carefully before fitting and operating the rooflights.**

**Important: We cannot be held responsible for incorrect fitting, handling or operation.**

**Any product faults relating to the production and materials used should be notified to us via an authorised dealer immediately.**

## Fitting Instructions

### Warning!



Never stand on the dome of the rooflight! (picture 1)

### **Fitting position**



Choose a fitting position that will not interfere with other roof mounted components (e.g. roof-racks/antenna's etc.) and avoid internally installed electrical cables and furniture, which could impede the correct operation of the rooflight.

The rooflight should only be fitted to a flat roof surface, both internally and externally.

### **Aperture size**

400x400 mm (see technical data page 6 - 7)

### **Roof thickness**

Ensure the correct rooflight is selected for the roof thickness (for available size options see page 6).

### **Fitting direction**

Rooflights must only be fitted with the operating handles facing the front and rear of the vehicle, not across the vehicle.

### **Fixing screws**

Secure only with pan, or round headed screws (not supplied), 3,5 mm/ head according to DIN ISO 7049 (DIN7981).

Screw size: When fully tightened the screw should enter the outer frame about 10 mm



Do not use countersunk screws as they will damage the rooflight frame (see picture 4).

### **Sealing**



Use only long term flexible sealant, suitable for external use, (not supplied), and also suitable for the material of the upper frame. Consult your sealant supplier.

### **Fitting**

Before fitting the rooflight remove the profiles covering the flynet and blind rollers. These are temporarily/partially fitted into place when new. PLEASE NOTE: When fully fitted these profiles cannot be removed without being damaged. It is therefore important to make sure the rooflight is fitted and operates correctly, before fully installing the profiles.

Correctly align the upper and lower frames and secure evenly with the screws. Do not over-tighten as this may damage the frame, or affect the correct operation of the rooflight. If the inner frame starts to distort, the correct torque has been reached (picture 2 - 3).

## Operation Instruction

### Instruction for use

The rooflight can be opened fully, or in four different directions, so that the dome can be angled against driving weather conditions. To open squeeze the locks (optional) into the handles and push open. To open the flynet, pull down on the handle. Do not open more than 90°, to avoid damaging the hinges. When closing the flynet click back into place. The roller blind (optional) can only be operated with the flynet in the open position.

### Free-air-flow



When closed there is a free airflow through the rooflight, which must be kept free at all times (see technical data page 6-7)

### Before driving



IMPORTANT: All rooflights must be closed and locked down before travelling (see picture 5-6)

## Care Instructions

### Cleaning



The rooflight should only be washed by hand, using a sponge with plenty of clean water to avoid scratching. Caustic detergents and solvents may attack the plastic and make it brittle or disintegrate.

For easier cleaning of the dome it can be removed from the frame by releasing the four screws holding the handle arms (Models from March 2008, Torx TK9 screws. Earlier models had cross recess screws) (see picture 7).

Make sure that only the original screws are used when replacing the dome and that they enter the thread in the plastic correctly. Do not over-tighten.



Never remove the screws holding the dome and the handles together (see picture 8). These are secured by a torque screwdriver and should only be handled by an approved dealers.

Remove the flynet, (with optional roller blind if fitted). The flynet is clipped into place, and is removed by first opening fully and pulling away from the frame. Reverse the process to install. Attention: to avoid damage, do not bend the flynet frame. Clean the flynet mesh and the roller fabric (if fitted) the same way as the dome, making sure that the metal components of the blind remain dry.

## **Technical Information**

### **Product description**

- Clear or opaque domes with free airflow
- Spring assisted mechanism, with locks
  - concealed fixing screws
- Removable flynet, optional roller blind
- Free airflow is calculated with roller closed
- ECE R43 approval for installation in caravans and motorhomes  
(Please ask for detailed informations!)

### **Technical Data:**

Aperture:	400 x 400 mm
Corner radius:	R = 25 mm
Size dome model 42:	470 x 470 mm
all other models:	560 x 560 mm
Height over roof: model 42:	91 mm
model 44/ 4400:	117 mm
model 46/ 4600:	92 mm
Free-air-flow:	Please refer to model options!
Outer frame/ dome material:	Polypropylene

## Technical Information

### Model Options:

#### **Model 42 (opaque dome)**

<b>white RAL 9001</b>	<b>grey</b>	<b>beige</b>	<b>roller</b>	<b>net</b>	<b>roof thickness</b>	<b>air-flow</b>	<b>weight</b>
420VNW	420VNG	420VNB	---	X	24 - 56 mm	150 cm <sup>2</sup>	2250 g
420VNRW	420VNRG	420VNRB	X	X	24 - 56 mm	150 cm <sup>2</sup>	2390 g
421VNW	421VNG	421VNB	---	X	42 - 70 mm	150 cm <sup>2</sup>	2340 g
421VNRW	421VNRG	421VNRB	X	X	42 - 70 mm	150 cm <sup>2</sup>	2480 g
420VNW-3	420VNG-3	420VNB-3	---	X	24 - 56 mm	30 cm <sup>2</sup>	2250 g
420VNRW-3	420VNRG-3	420VNRB-3	X	X	24 - 56 mm	30 cm <sup>2</sup>	2390 g
421VNW-3	421VNG-3	421VNB-3	---	X	42 - 70 mm	30 cm <sup>2</sup>	2340 g
421VNRW-3	421VNRG-3	421VNRB-3	X	X	42 - 70 mm	30 cm <sup>2</sup>	2480 g

### Model Options:

#### **Model 44 (opaque dome)**

<b>white RAL 9001</b>	<b>grey</b>	<b>beige</b>	<b>roller</b>	<b>net</b>	<b>roof thickness</b>	<b>air-flow</b>	<b>weight</b>
440VNW	440VNG	440VNB	---	X	24 - 56 mm	95 cm <sup>2</sup>	2670 g
440VNRW	440VNRG	440VNRB	X	X	24 - 56 mm	95 cm <sup>2</sup>	2810 g
441VNW	441VNG	441VNB	---	X	42 - 70 mm	95 cm <sup>2</sup>	2770 g
441VNRW	441VNRG	441VNRB	X	X	42 - 70 mm	95 cm <sup>2</sup>	2910 g

#### **Model 4400 (clear dome)**

<b>white RAL 9001</b>	<b>grey</b>	<b>beige</b>	<b>Roller</b>	<b>net</b>	<b>roof thickness</b>	<b>air-flow</b>	<b>weight</b>
4400VNW	4400VNG	4400VNB	---	X	24 - 56 mm	95 cm <sup>2</sup>	2670 g
4400VNRW	4400VNRG	4400VNRB	X	X	24 - 56 mm	95 cm <sup>2</sup>	2810 g
4410VNW	4410VNG	4410VNB	---	X	42 - 70 mm	95 cm <sup>2</sup>	2770 g
4410VNRW	4410VNRG	4400VNRB	X	X	42 - 70 mm	95 cm <sup>2</sup>	2910 g

**New colour 1.7.2008:**

**Old white RAL 9010 still available**

**Please use colour code „AW“ in art-no. (instead of „W“)**

## Technical Information

### Model Options

#### **Model 46 (opaque dome)**

<b>white RAL 9001</b>	<b>grey</b>	<b>beige</b>	<b>roller</b>	<b>net</b>	<b>roof thickness</b>	<b>air-flow</b>	<b>weight</b>
460VNW	460VNG	460VNB	---	X	24 - 56 mm	150 cm <sup>2</sup>	2715 g
460VNRW	460VNRG	460VNRB	X	X	24 - 56 mm	150 cm <sup>2</sup>	2855 g
461VNW	461VNG	461VNB	---	X	42 - 70 mm	150 cm <sup>2</sup>	2805 g
461VNRW	461VNRG	461VNRB	X	X	42 - 70 mm	150 cm <sup>2</sup>	2945 g
460VNW-3	460VNG-3	460VNB-3	---	X	24 - 56 mm	30 cm <sup>2</sup>	2715 g
460VNRW-3	460VNRG-3	460VNRB-3	X	X	24 - 56 mm	30 cm <sup>2</sup>	2855 g
461VNW-3	461VNG-3	461VNB-3	---	X	42 - 70 mm	30 cm <sup>2</sup>	2805 g
461VNRW-3	461VNRG-3	461VNRB-3	X	X	42 - 70 mm	30 cm <sup>2</sup>	2945 g

#### **Model 4600 (clear dome)**

<b>white RAL 9001</b>	<b>grey</b>	<b>beige</b>	<b>roller</b>	<b>net</b>	<b>roof thickness</b>	<b>air-flow</b>	<b>weight</b>
4600VNW	4600VNG	4600VNB	---	X	24 - 56 mm	150 cm <sup>2</sup>	2715 g
4600VNRW	4600VNRG	4600VNRB	X	X	24 - 56 mm	150 cm <sup>2</sup>	2855 g
4610VNW	4610VNG	4610VNB	---	X	42 - 70 mm	150 cm <sup>2</sup>	2805 g
4610VNRW	4610VNRG	4610VNRB	X	X	42 - 70 mm	150 cm <sup>2</sup>	2945 g
4600VNW-3	4600VNG-3	4600VNB-3	---	X	24 - 56 mm	30 cm <sup>2</sup>	2715 g
4600VNRW-3	4600VNRG-3	4600VNRB-3	X	X	24 - 56 mm	30 cm <sup>2</sup>	2855 g
4610VNW-3	4610VNG-3	4610VNB-3	---	X	42 - 70 mm	30 cm <sup>2</sup>	2805 g
4610VNRW-3	4610VNRG-3	4610VNRB-3	X	X	42 - 70 mm	30 cm <sup>2</sup>	2945 g

**New colour 1.7.2008:**

**Old white RAL 9010 still available**

**Please use colour code „AW“ in art-no. (instead of „W“)**

# Spare parts

Model 42...

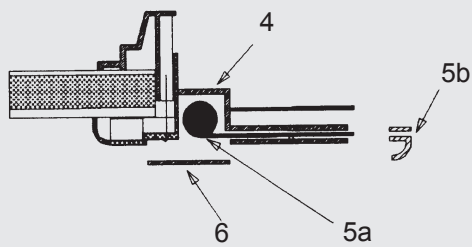
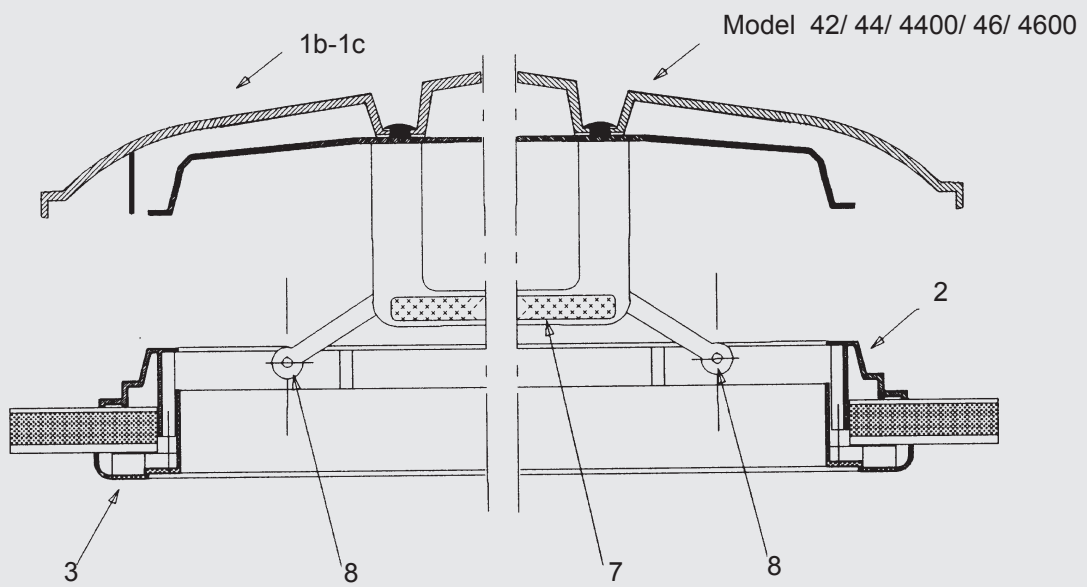
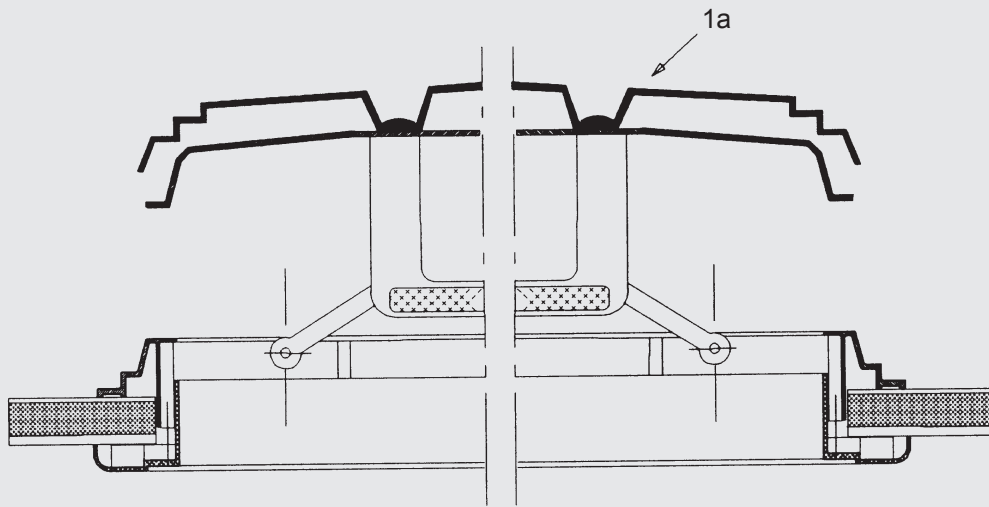



## Spare parts

No.	Spare parts	Colour frame:		
		beige	white RAL 9001	grey
1a	<i>Replacement dome model 42</i> opaque - 150 cm <sup>3</sup> air-flow opaque - 30 cm <sup>3</sup> air-flow	420.52VB 420.52VB-3	420.52VW 420.52VW-3	420.52VG 420.52VG-3
1b	<i>Replacement dome model 46 / 4600</i> opaque - 150 cm <sup>3</sup> air-flow opaque - 30 cm <sup>3</sup> air-flow clear -150 cm <sup>3</sup> air-flow clear - 30 cm <sup>3</sup> air-flow	460.52VB 460.52VB-3 4600.52VB 4600.52VB-3	460.52VW 460.52VW-3 4600.52VW 4600.52VW-3	460.52VG 460.52VG-3 4600.52VG 4600.52VG-3
1c	<i>Replacement dome model 44 / 4400</i> opaque - 150 cm <sup>3</sup> air-flow opaque - 30 cm <sup>3</sup> air-flow clear - 150 cm <sup>3</sup> air-flow clear - 30 cm <sup>3</sup> air-flow	440.52VB 440.52 VB-3 4400.52VB 4400.52VB-3	440.52VW 440.52VW-3 4400.52VW 4400.52VW-3	440.52VG 440.52VG-3 4400.52VG 4400.52VG-3
7	Locks; 1 set supplied in polybag with hanger	420.99S	420.99S	420.99S
	<u>Replacement frame, roller, net for rooflights</u>			
2	Outer frame for Mod. 42/ 44/ 4400/ 46/ 4600 for roof thickness 24 - 56 mm for roof thickness 42 - 70 mm	420.21B 421.21B	420.21W 421.21W	420.21G 421.21G
3a	Inner frame	420.22B	420.22W	420.22G
4	Flynet frame with net	420.5B	420.5W	420.5G
4a	Flynet frame with net and roller	420.5RB	420.5RW	420.5RG
5a	Roller complete	420.7B	420.7W	420.7G
5b	Roller blind handle profile 2-parts	420.2B	420.2W	420.2G
6	Cover for roller blind aperture	420.6B	420.6W	420.6G
8	Torx screws for handles	8000.4	8000.4	8000.4

**New colour 1.7.2008:**

**Old white RAL 9010 still available**

**Please use colour code „AW“ in art-no. (instead of „W“)**